

DESCRIPTION

The EV2633A-R-00A is the evaluation board designed to demonstrate the capabilities of MPS' MP2633A, a highly-integrated, flexible switch-mode battery charge management and system power path management device for a single-cell Li-ion and Li-Polymer battery used in a wide range of portable applications.

EV2633A uses two operation modes -- charge mode and boost mode -- to allow management of system and battery power based on the state of the input.

When input power is present, the board charges a single-cell battery with a programmable charge current of up to 1.5A.

In the absence of an input source, the board switches to boost mode through the MODE pin to power the SYS pins from the battery with a current up to 1A.

The evaluation board provides full-operating-status indication to distinguish charge mode from boost mode.

For guaranteed safe operation, the EV2633A has input-over-voltage protection, battery over-voltage protection, thermal shutdown, battery-temperature monitoring, and programmable timer to prevent prolonged charging of a dead battery.

ELECTRICAL SPECIFICATION

Parameter	Symbol	Value	Units
Input Voltage Range	V_{IN}	4.24 – 6	V
Charge Full Voltage	V_{BATT_Full}	4.2/ 3.6	V
Charge Current	I_{CHG}	1.5	A
Input Current Limit	I_{IN_LIM}	2	A
Battery Voltage	V_{BATT}	2.5 – 4.35	V
SYS Voltage Regulation	V_{SYS}	5	V
SYS Output Current Limit	I_{SYS}	1	A

FEATURES

- 4.5V-to-16V Input Voltage Range
- Input-Current-Based Power Management
- Up to 1.5A Programmable Charge Current
- Selectable 3.6V / 4.2V Charge Voltage with 0.5% Accuracy
- Battery Temperature Monitoring
- Full Operation Indicators
- Programmable Timer-Back-up Protection
- Battery-Reverse-Leakage Blocking
- Reverse-Boost-Operation for Powering System
- Up to 91% 5V Boost Mode Efficiency @ 1A
- Up to 1A Programmable Output Current Limit in Boost Mode

APPLICATIONS

- Sub-battery Applications
- Power-bank Applications for Smart-Phone, Tablet and Other Portable Devices

All MPS parts are lead-free and adhere to the RoHS directive. For MPS green status, please visit MPS website under Products, Quality Assurance page.

"MPS" and "The Future of Analog IC Technology", are Registered Trademarks of Monolithic Power Systems, Inc.

EV2633A-R-00A EVALUATION BOARD



(L x W x H) 6.1cm x 5.1cm x 1.3cm

Board Number	MPS IC Number
EV2633A-R-00A	MP2633A

EVALUATION BOARD SCHEMATIC

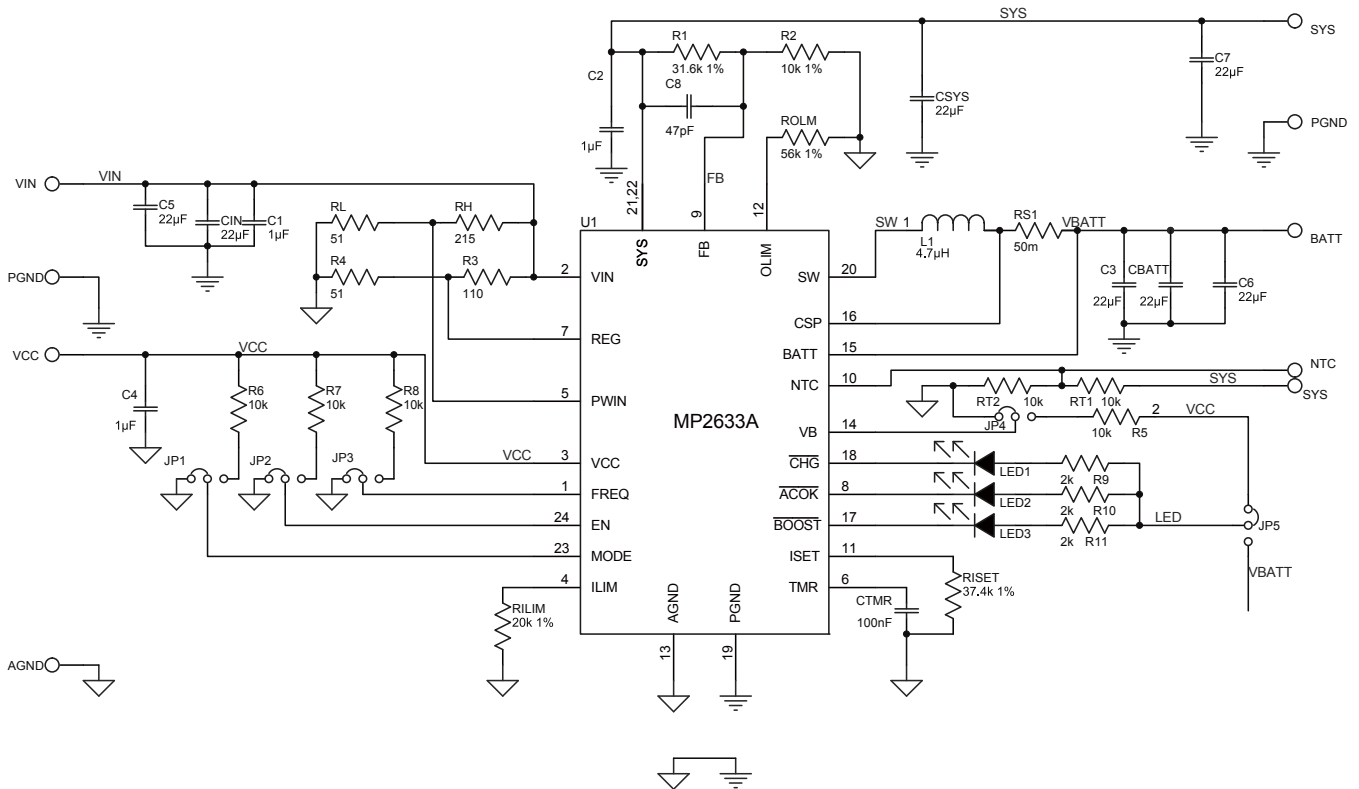

EV2633A-R-00A BILL OF MATERIALS

Qty	Ref	Value	Description	Package	Manufacture	Manufacture PN
1	C1	1 μ F	Ceramic Capacitor; 25V;X5R	CAP/0603	TDK	C1608X5R1E105K
1	C2	1 μ F	Ceramic Capacitor; 16V;X7R;	CAP/0603	muRata,	GRM188R71C105KA12D
4	C3,C7, CSYS, CBATT	22 μ F	Ceramic Capacitor; 10V;X7R;	CAP/1206	muRata	GRM31CR71A226KE15L
2	C4, CTMR	100nF	Ceramic Capacitor; 50V;X7R;	CAP/0603	muRata	GRM188R71H104KA93D
2	C5, C6	NC				
1	C8	47pF	Ceramic Capacitor; 50V;C0G;	CAP/0603	TDK	C1608C0G1H470J
1	CIN	22 μ F	Ceramic Capacitor; 25V;X5R;	CAP/1206	muRata	GRM31CR61E226KE15
1	L1	4.7 μ H	Inductor;4.7 μ H;	SMD	Würth	744311470
					Cooper	DR73-4R7-R
2	LED1, LED3	BL- HUF35A -TRB	LED;Red	LED/SMD/0805	BRIGHT LED	BL-HUF35A-TRB
1	LED2	HL-PSC- 2012H203 BC	LED;Blue	LED/SMD/0805	BRIGHT LED	HL-PSC-2012H203BC
1	R1	31.6k 1%	Film Resistor;1%;	RES/0603	Yageo	RC0603FR-0731K6L
4	R2,R5, RT1, RT2	10k 1%	Film Resistor;1%;	RES/0603	Yageo	RC0603FR-0710KL
1	R3	110	Film Resistor;1%	RES/0603	Yageo	RC0603FR-07110RL
2	R4, RL	51	Film Resistor;1%	RES/0603	Yageo	RC0603FR-0751RL
3	R6, R7, R8	10k	Film Resistor;5%;	RES/0603	Yageo	RC0603JR-0710K
3	R9,R10, R11	2k	Film Resistor;5%;1/10W	RES/0603	LIZ	CR0603JA0202G
1	RH	215	Film Resistor;1%	RES/0603	Yageo	RC0603FR-07215RL
1	RILIM	20k 1%	Film Resistor;1%;	RES/0603	Yageo	RC0603FR-0720KL
1	RISSET	37.4k 1%	Film Resistor;1%;	RES/0603	Yageo	RC0603FR-0737K4L
1	ROLM	56k 1%	Film Resistor;1%	RES/0603	Yageo	RC0603FR-0756KL
1	RS1	50m	Sense Resistor; 1%;1/2W;	RES/1206	Yageo	RL1206FR-070R050L
5	JP1, JP2, JP3, JP4, JP5		JUMPER/3P/DIP/2. 54mm			
1	U1			QFN24/4X4MM/EP	MPS	MP2633AGR

PRINTED CIRCUIT BOARD LAYOUT

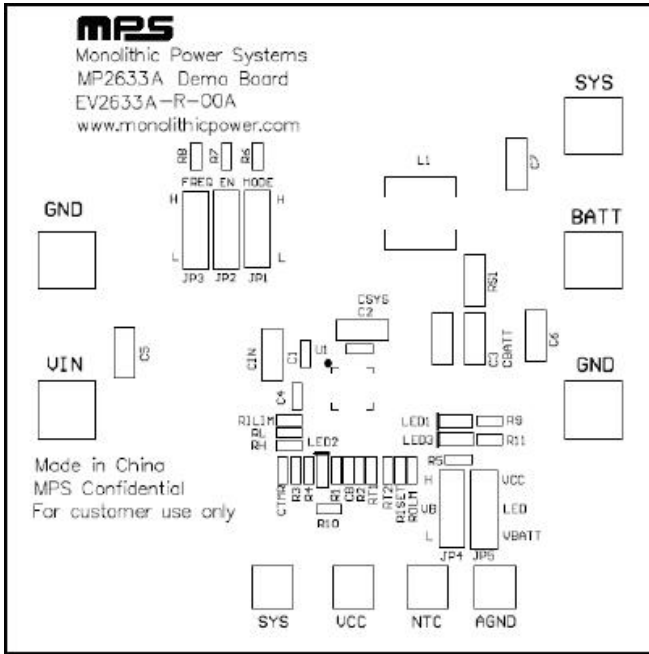

Figure 1: Top Silkscreen Layer

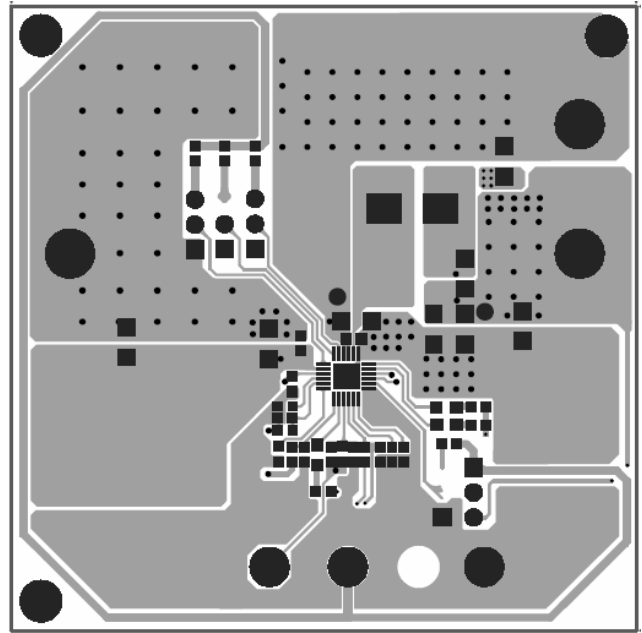

Figure 2: Top Layer

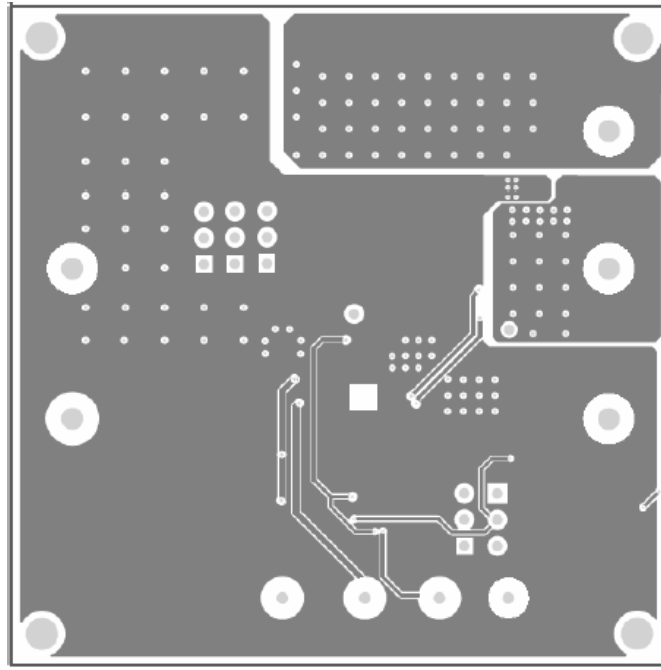

Figure 3: Bottom Layer

QUICK START GUIDE

This board is designed for the MP2633A, a stand-alone switch-mode battery charge management and system power path management device with integrated reverse directional boost from BATT to SYS. The board's layout accommodates most commonly-used capacitors. The default function of this board is preset at charger mode, and the charge full voltage is preset to 4.2V for 1 cell Li-Ion battery.

Charge Mode Setting

1. Input Over Voltage Limit

The MP2633A has a PWIN pin to monitor the input voltage. Once the voltage input voltage at PWIN pin exceeds 1.15V, the input to system path is cut off to protect the device from being damaged. The maximum input is 6V, and the external resistor divider must meet the following equation:

$$\frac{V_{PWIN}}{V_{IN}} = \frac{1.15}{6} = \frac{R_L}{R_H + R_L} \quad (1)$$

Assume that $R_L=51\Omega$, then R_H is 215Ω .⁽¹⁾

2. REG Voltage

The REG pin is the input-voltage feedback. Connect this pin to the tap of an external resistor divider from VIN to GND. The voltage at this pin must always exceed 1.2V during normal operation.

$$V_{REG} = \frac{R_4}{R_3 + R_4} \times V_{IN_MIN} > 1.2V \quad (2)$$

If $V_{IN_MIN}=4.25V$, given $R_4=51\Omega$, then $R_3=127\Omega$.⁽¹⁾

3. Input Current Limit

An input current limit can be set slightly below the input source's maximum current rating. When the input current hits this limit, the charge current will be decreased to keep the input current constant at the limit value to initially power the system. R_{ILIM} – the resistor connected to the ILIM pin -- programs this limit. To set the input current limit at 2A, use an R_{ILIM} of 20k Ω .

$$I_{ILIM}(A) = \frac{40.5(kV)}{R_{ILIM}(k\Omega)} \quad (3)$$

4. Charge-Full Voltage

To set the charge full voltage, either leave VB pin floating, or connect it to high logic for 4.2V and to connect to GND for 3.6V.

5. Charge Current

The charge current can be programmed via both RS1 and Riset. With given $RS1=50m\Omega$, determine the charge using the following formula:

$$I_{CHG}(A) = \frac{70(k\Omega)}{R_{ISET}(k\Omega)} \times \frac{40(mV)}{RS1(m\Omega)} \quad (4)$$

For example, for a charge current of 1.5A, use a 37.4k Ω R_{ISET} .

6. Charge Timer

The MP2633A has a charge timer as an external precaution against charging damaged batteries. The total charge time can be set as:

$$\tau_{\text{TOTAL_TMR}} = 6\text{Hours} \times \frac{C_{\text{TMR}}(\mu\text{F})}{0.1\mu\text{F}} \times \frac{1\text{A}}{I_{\text{CHG}}(\text{A})} \quad (5)$$

So if the charge current is 1.5A, a C_{TMR} of 0.1 μF provides a $t_{\text{TOTAL_TMR}}$ of 4hours.

Boost Mode Setting

1. System Output Voltage

The MODE pin can enable or disable the EV2633A when in boost mode. The resistor divider—R1 and R2 – can adjust the output voltage as per the following equation:

$$V_{\text{SYS_REG}}(\text{V}) = 1.2\text{V} \times \frac{R1+R2}{R2} \quad (6)$$

Select R1 and R2 as 31.6k Ω and 10k Ω respectively, for a system voltage of 5V.

2. System-Output-Current Limit

Set the system-output-current limit in boost mode for the EV2633A to operate like a standard adapter. Set the output current limit as per the following equation:

$$I_{\text{OLIM}}(\text{A}) = \frac{70(\text{k}\Omega)}{R_{\text{OLIM}}(\text{k}\Omega)} \times \frac{40(\text{mV})}{RS1(\text{m}\Omega)} \quad (7)$$

Others

1. Operating Frequency Setting

The operation frequency can be programmable to optimize the design for both charge and boost modes. Set the frequency to 1.2MHz by connecting the FREQ pin to “H” or leaving the FREQ pin floating, while set to 600kHz by connecting the FREQ pin to “L”.

For the other detailed description on the operation of the MP2633A, please refer to the datasheet.

Note: 1. Considering these resistors (R3, R4, RH, RL) as dummy loads at input port, Use resistors in the hundreds-of-ohms range to increase the power off speed.

EQUIPMENT REQUIREMENT

Evaluation requires the following equipments:

1. DC power source. The output voltage should exceed 6V, and output current greater than 1.5A.
2. Battery simulator or a single-cell battery pack. The battery simulator' output rating should exceed 4.5V/1.5A. When using a real battery pack, please observe all precautions on the battery manufacturer's data sheet first and then ensure the charger's setting doesn't exceed the battery's absolute maximum specification.
3. An oscilloscope. A single voltage probe and a single current probe are required at least.
4. A multi-meter.

Charge Function

1. Connect the jumper "EN" to "H" and the "MODE" to "L" to shunts, respectively!
2. Attach the positive and negative ends of the battery to the "BATT" and "GND" terminals, respectively. If it's a battery simulator, please preset the voltage to 3.8V (typical value) first.
3. Preset the DC power source to 5V. Then attach the DC output port and ground to the "VIN" and "GND" terminals, respectively.
4. Turn on the DC power source. The charger will start. Use the oscilloscope to verify that the 1.5A charge current is being delivered to the battery.
5. Remove the shunt between the "EN" and "L" to disable charging.
6. Re-insert the shunt between the "EN" and "H" to enable charging.

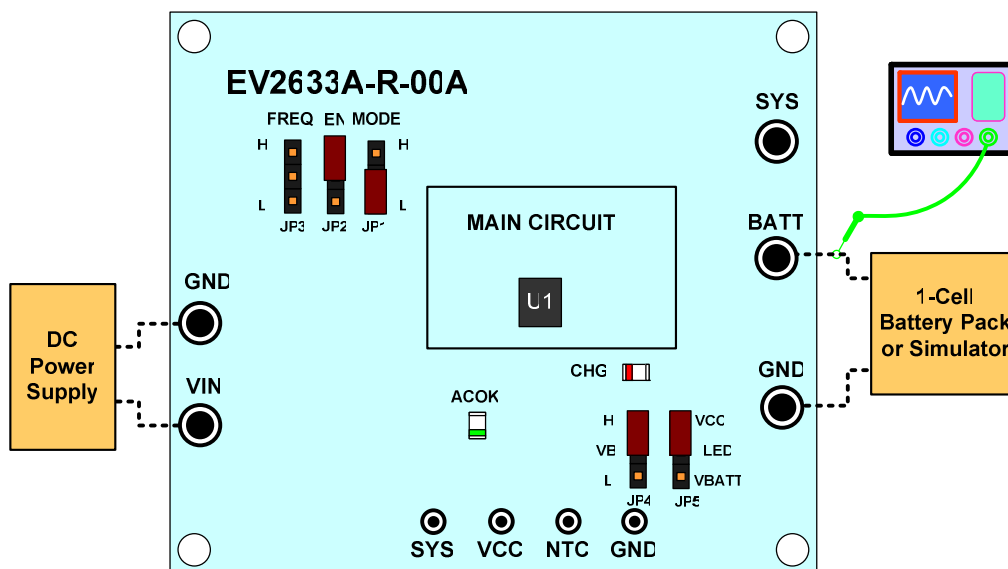

Figure 4—Setup for Charge Mode

Boost Function

1. Connect the jumper “MODE” to “H” and the “EN” to “L” with shunts respectively!
2. Attach the load to the “SYS” and “GND” terminals respectively.
3. Attach the positive and negative ends of the battery to the “BATT” and “GND” terminals respectively. If it’s a battery simulator, please preset the voltage to 3.8V (typical value) firstly. The boost will start to work. Verify the system output current is limited at 1A.
4. Remove the shunt between the “MODE” and “H” to disable boost.
5. Install the shunt between the “MODE” and “H” to enable boost.

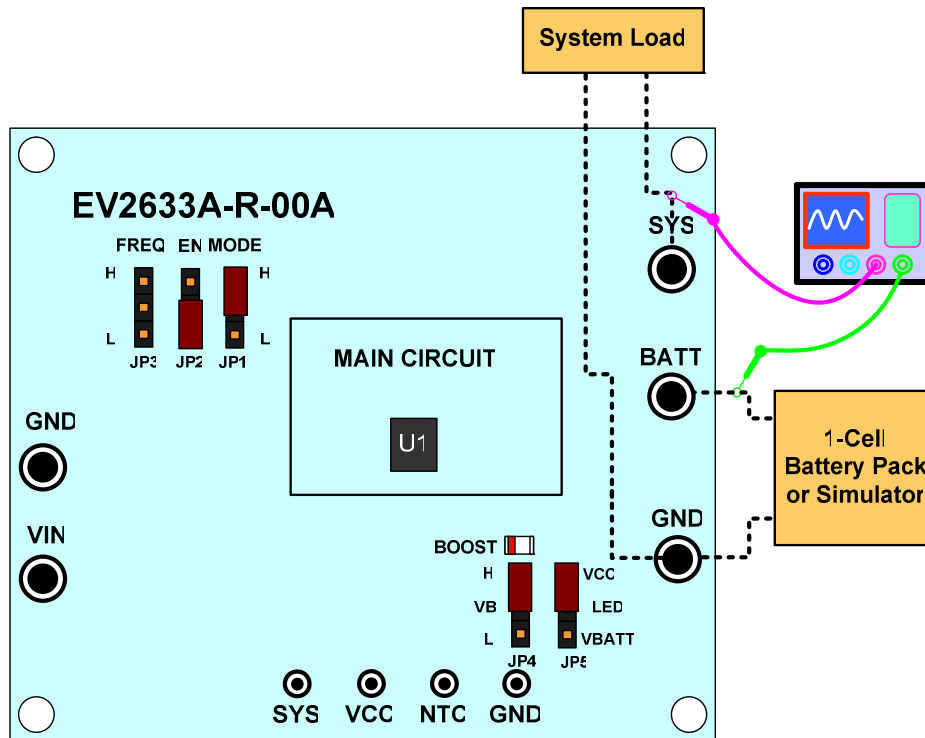

Figure 5—Setup for Boost Mode

NOTICE: The information in this document is subject to change without notice. Please contact MPS for current specifications. Users should warrant and guarantee that third party Intellectual Property rights are not infringed upon when integrating MPS products into any application. MPS will not assume any legal responsibility for any said applications.