

DESCRIPTION

The EV2671DL-00A is an evaluation board for the MP2671, the high-performance protection chip for battery charger.

By integrating high voltage input protection into the charger IC, the MP2671 can tolerate an input surge up to 28V.

The MP2671 features input over voltage protection (OVP), battery voltage over voltage protection (BOVP), and over charge current protection (OCP). Additionally, MP2671 also monitors its own internal temperature and provides thermal protection (OTP). The device also provides fault indication. Any protection event can be indicated by customer.

ELECTRICAL SPECIFICATION

Parameter	Symbol	Value	Units
Input Voltage	V_{IN}	5	V
Limit Current	I_{LIM}	1	A

FEATURES

- Input Surge up to 28V
- Input Over voltage protection in 1us.
- Proprietary Battery Over-Voltage Protection
- Programmable Charge Current Protection Limit Value.
- Temperature Monitoring and Protection
- Fault Indication
- Enable Input
- Fully Assembled and Tested

APPLICATIONS

- Cell Phones
- MP3 Players
- Smart Phones
- PDAs
- Digital Cameras
- Desktop Chargers

"MPS" and "The Future of Analog IC Technology" are Registered Trademarks of Monolithic Power Systems, Inc.

EV2671DL-00A EVALUATION BOARD



(L x W x H) 1.4" x 1.1" x 0.5" (3.5cm x 2.8cm x 1.0cm)

Board Number	MPS IC Number
EV2671DL-00A	MP2671DL

EVALUATION BOARD SCHEMATIC

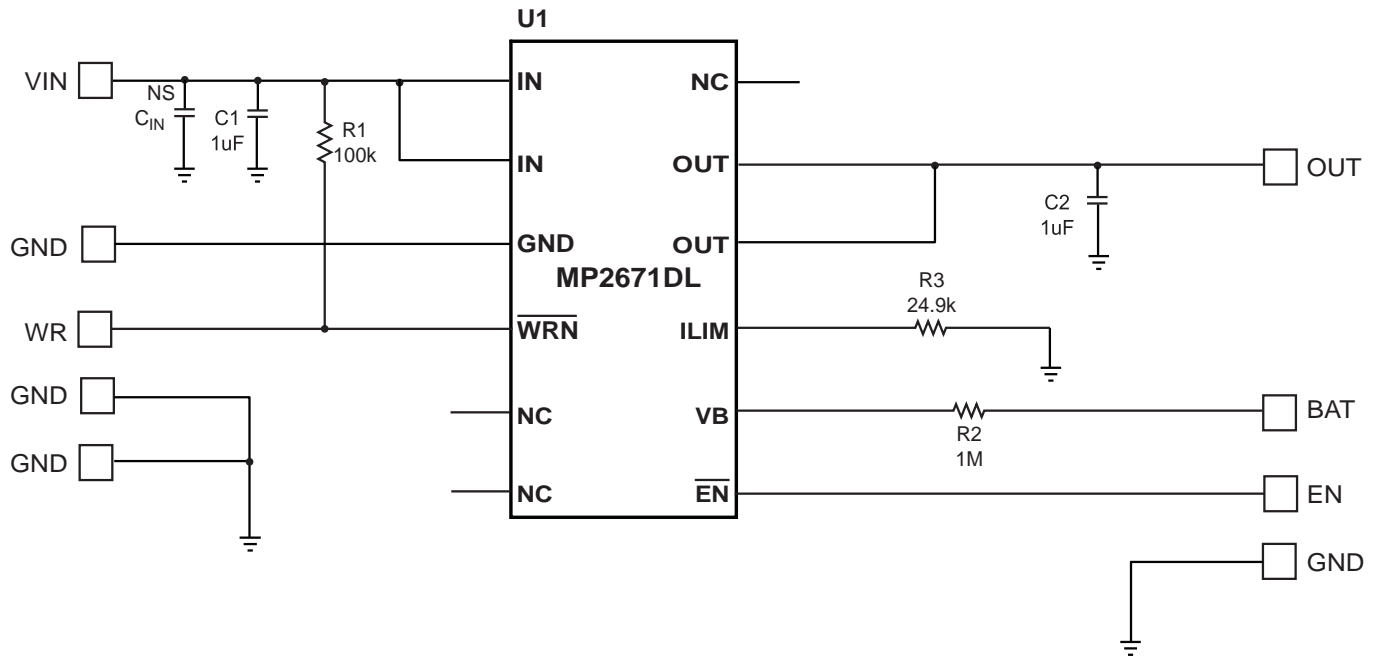

EV2671DL-00A BILL OF MATERIALS

Qty	RefDes	Value	Description	Package	Manufacturer	Manufacturer P/N
1	C1	1uF	Ceramic Cap, 50V, X7R	SM0805	muRata	GRM21BR71H105KA1
1	C2	1uF	Ceramic Cap, 25V, X7R	SM0805	TDK	C2012X7R1E105K
1	C _{IN}	NS		SM1206		
1	R1	100K		SM0603	any	
1	R2	1Meg	Film Res, 5%	SM0603	Yageo	RC0603JR-071ML
1	R3	24.9k	Film Res, 1%	SM0603	Yageo	RC0603FR-0724K9L
1	U1		Charge Protection Device	QFN12	MPS	MP2671DL

PRINTED CIRCUIT BOARD LAYOUT

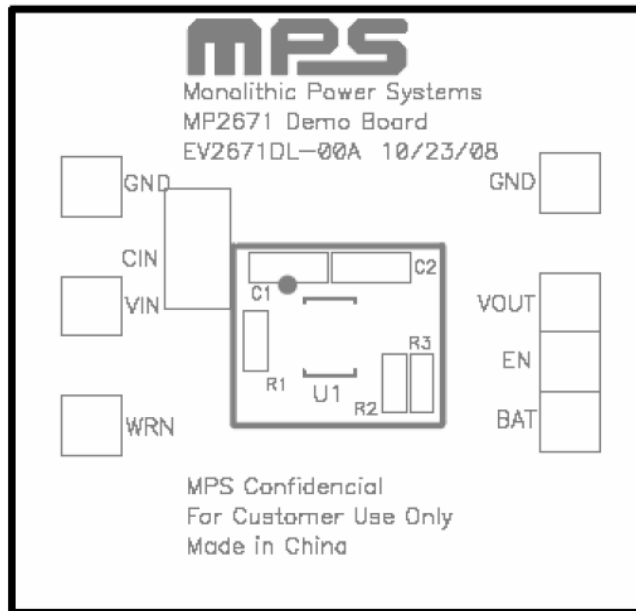

Figure 1—Top Silk Layer

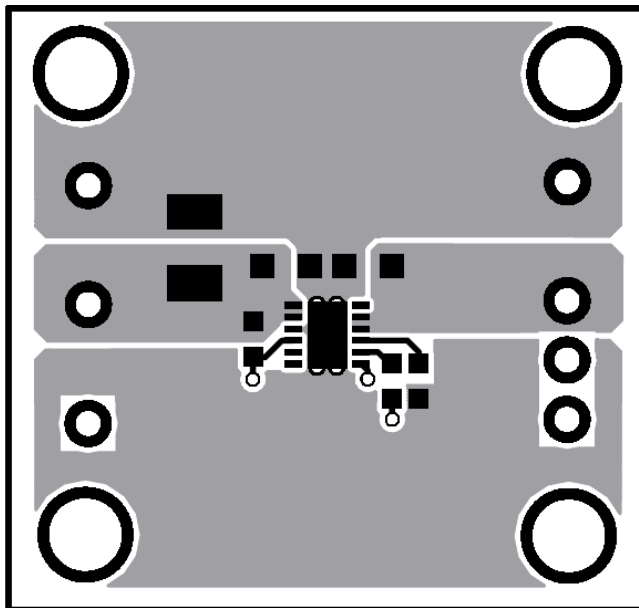

Figure 2—Top Layer

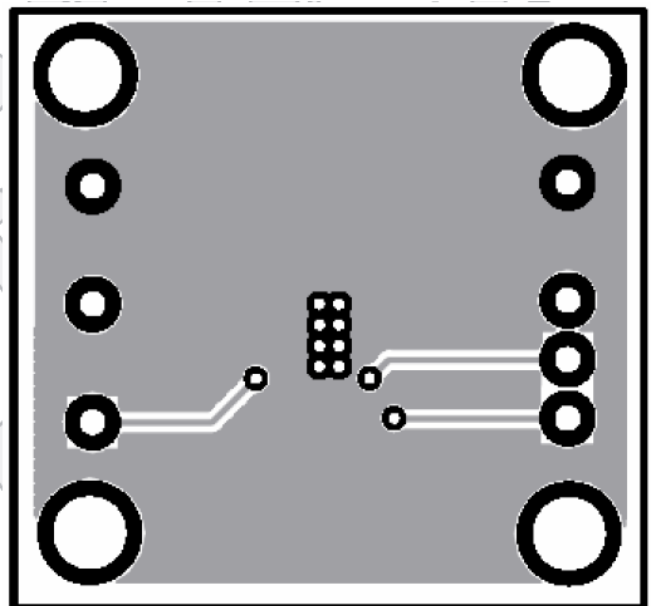

Figure 3—Bottom Layer

QUICK START GUIDE

1. The board layout accommodates most commonly used capacitors and resistors.
2. Attach the positive and negative terminators of the load to the OUT and GND pins respectively.
3. Attach the input voltage (max 28V) and input ground to the VIN and GND pins respectively. It will start up when V_{in} is higher than 2.7V and shut down when V_{in} is below 2.4V.
4. MP2671 will start up automatically with floating \overline{EN} pin.

If MP2671 is controlled by \overline{EN} , drive V_{EN1} below 0.4V to enable the IC and drive it higher than 1.5V to disable MP2671.

5. If the input voltage is higher than 6V, MP2671 will detect this input OVP fault, and drop the voltage of OUT pin down to 0V. There is no input to the charger system.
6. The battery over voltage is indicated by VB pin, if the Voltage of VB is higher than 4.4V, the voltage of OUT pin will drop to 0V too. The resistor R_{VB} from BAT to VB pin provides a current limit, the recommended value is 200k Ω to 1M Ω .
7. The current limit function of MP2671 is to prevent charging the system with an excessive current, the OCP threshold can be set by the resistor R_{LIM} :

$$I_{LIM} (A) = \frac{0.8V}{R_{LIM}} \times 31250 = \frac{25000}{R_{LIM} (\Omega)}$$

The limit value of the board is set at 1A.

8. WRN pin is an open drain output that indicates a LOW signal when any of the three protection events happens. So connect R1 from WRN to VIN pin, the recommended value for R1 is 10k Ω to 100k Ω .

NOTICE: The information in this document is subject to change without notice. Please contact MPS for current specifications. Users should warrant and guarantee that third party Intellectual Property rights are not infringed upon when integrating MPS products into any application. MPS will not assume any legal responsibility for any said applications.