

## DESCRIPTION

The EV3908DK-00B is a synchronous boost converter evaluation board for the MP3908DK. It is configured to provide a regulated 19V output at up to 5A load current from a 7V-17V input. The output is adjustable by changing feedback resistors on the evaluation board.

The demo board uses the external 6.7mΩ resistor to sense the current and MP6901DS to drive a low Ron mosfet as rectifier to achieve high efficiency. MP6901DS is a Low-Drop Diode Emulator IC which works with an external switch to replace Schottky diode.

## ELECTRICAL SPECIFICATIONS

Parameter	Symbol	Value	Units
Input voltage	$V_{IN}$	7–17	V
Input current	$I_{IN}$	0–14.5	A
Output voltage	$V_O$	19	V
Output Current	$I_O$	5	A

## FEATURES

- High Efficiency
- Synchronous Rectification with MP6901DS
- Current Mode Control
- Soft-Start
- Under-Voltage Lockout
- 250KHz Constant Frequency Operation

## APPLICATIONS

- Backup Battery Charger for Notebook

"MPS" and "The Future of Analog IC Technology" are Registered Trademarks of Monolithic Power Systems, Inc.

## EV3908DK-00B EVALUATION BOARD



(L x W x H) 4.3" x 3.1" x 0.6"  
11cm x 8cm x 1.4cm

Board Number	MPS IC Number
EV3908DK-00B	MP3908DK

Efficiency vs.  
Load Current

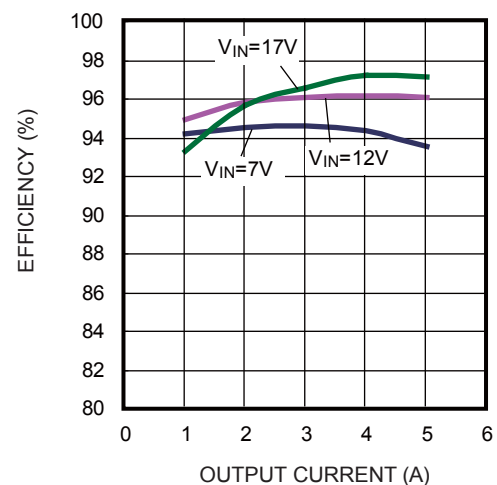

**EVALUATION BOARD SCHEMATIC**

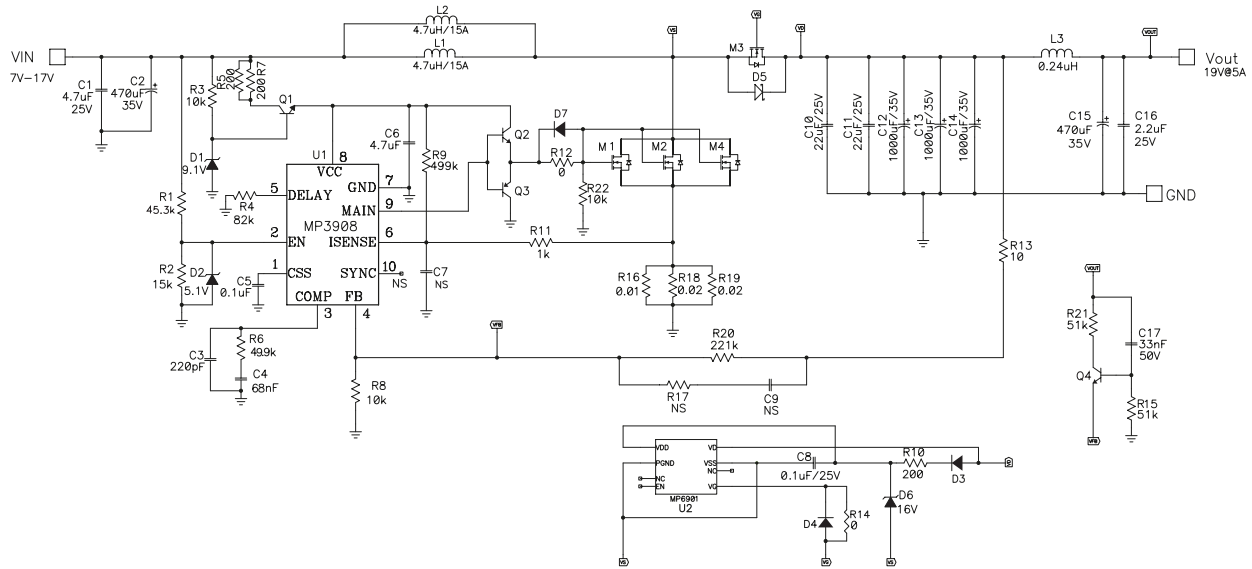

**EV3908DK-00B BILL OF MATERIALS**

Qty	Ref	Value	Description	Package	Manufacturer	Manufacturer P/N
1	C1	4.7uF	Ceramic Cap., 25V, X7R	1210	Any	
2	C2, C15	470uF	Electrotype Cap, 35V	DIP	JiangHai	CD110-35V470
1	C3	220pF	Ceramic Cap., 50V, X7R	0603	Any	
1	C4	68nF	Ceramic Cap, 50V, X7R	0603	Any	
1	C5	0.1uF	Ceramic Cap, 16V, X7R	0603	Any	
1	C6	4.7uF	Ceramic Cap, 16V, X5R	0805	Any	
2	C7, C9	NS	No Stuffed			
1	C8	0.1uF	Ceramic Cap., 25V, X7R	0805	Any	
2	C10, C11	22uF	Ceramic Cap., 25V, X7R	1210	Any	
3	C12, C13, C14	1000uF	Electrotype Cap, 35V	DIP	JiangHai	CD287-35V1000
1	C16	2.2uF	Ceramic Cap, 25V, X7R	0805	Any	
1	C17	33nF	Ceramic Cap, 50V, X7R	0603	TDK	C1608X7R1H333K
1	R1	45.3kΩ	Film Res., 5%	0603	Any	
1	R2	15kΩ	Film Res., 5%	0603	Any	
3	R3, R8, R22	10kΩ	Film Res., 1%	0603	Yageo	RC0603FR-0710KL
1	R4	82kΩ	Film Res., 5%	0603	Any	

**EV3908DK-00B BILL OF MATERIALS (continued)**

Qty	Ref	Value	Description	Package	Manufacturer	Manufacturer P/N
3	R5, R7, R10	200Ω	Film Res., 5%	0603	Any	
1	R6	49.9kΩ	Film Res., 1%	0603	Any	
1	R9	499kΩ	Film Res., 1%	0603	Yageo	RC0603FR-07499KL
1	R11	1kΩ	Film Res., 5%	0603	Any	
2	R12,R14	0Ω	Film Res., 5%	0603	Any	
1	R13	10Ω	Film Res., 1%	0603	Yageo	RC0603FR-0710RL
2	R15,R21	51kΩ	Film Res., 1%	0603	Yageo	RC0603FR-0751KL
1	R16	10mΩ	Film Res., 1%	2512	CYNTEC	RL3264-6-R010-FN
1	R17	NS	No Stuffed			
2	R18, R19	20mΩ	Film Res., 1%	2512	CYNTEC	RL3264-6-R020-FN
1	R20	221kΩ	Film Res., 1%	0603	Yageo	RC0603FR-07221KL
1	D1	9.1V	Diode Zener, 5mA	SOD123	Diodes	BZT52C9V1
1	D2	5.1V	Diode Zener, 5mA	SOD323	Diodes	BZT52C5V1S-7
3	D3,D4,D7	Diode	75V, 0.15A	SOD323	Diodes	IN4148WS-7-F
1	D5		Schottky Diode	SMB	Diodes	B230
1	D6	16V	Diode Zener, 5mA	SOD123	Diodes	BZT52C16
2	L1, L2	4.7uH	Inductor, 15A, 7.7mΩ	SMD	Würth	7443551470
			Inductor, 15A, 8mΩ	SMD	Yageo	SPMC127T-4R7M
1	L3	0.24uH	Inductor, 28A		Würth	744314024
3	M1,M2,M4	Mosfet	N-CH, 30V, 12.5mΩ, 12nC	Powerpak SO-8	Vishay	Si7384DP
			N-CH, 30V, 9.5mΩ, 11.5nC	Powerpak SO-8	Vishay	Si7386DP
1	M3	Mosfet	N-CH, 30V, 20mΩ, 12.5nC	TO-252	Analog Power	AM50N03-12D
			N-CH, 30V, 24mΩ, 8.5nC	TO-252	Vishay	SUD50N03-16P
2	Q1,Q2	Transistor	NPN	SOT-23	Changdian	S8050
1	Q3	Transistor	PNP	SOT-23	Changdian	S8550
1	Q4	Transistor	NPN	SOT-23	On Semiconductor	MMBT3904LT1
1	U1		DC-DC Converter	MSOP10	MPS	MP3908DK
1	U2		Low-Drop Diode Emulator	SO-8	MPS	MP6901DS-LF

**PRINTED CIRCUIT BOARD LAYOUT**

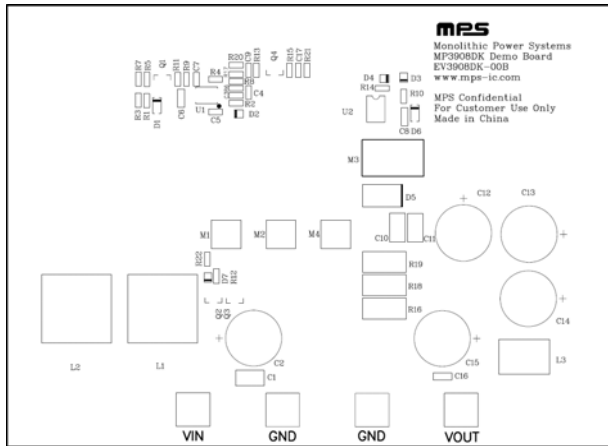

**Figure 1—Top Silk Layer**

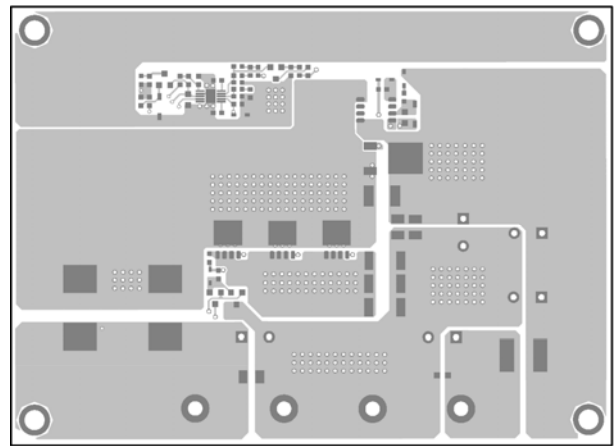

**Figure 2—Top Layer**

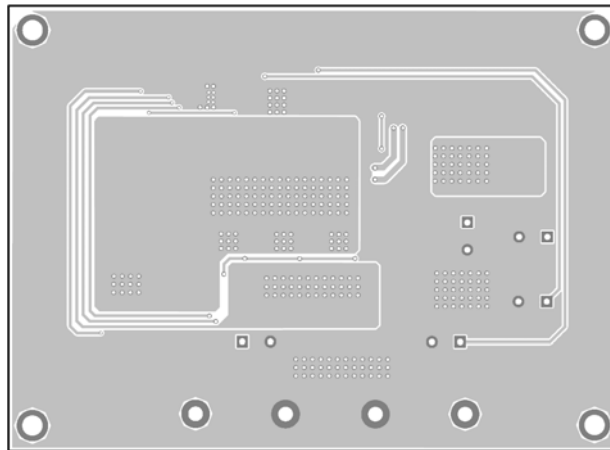

**Figure 3—Bottom Layer**

## QUICK START GUIDE

1. Connect the positive and negative terminals of the load to VOUT and GND pins, respectively.
2. Preset the power supply output to 7V – 17V and turn off the power supply.
3. Connect the positive and negative terminals of the power supply output to the VIN and GND pins, respectively.
4. Turn the power supply on. The board will start up automatically.

**NOTICE:** The information in this document is subject to change without notice. Users should warrant and guarantee that third party Intellectual Property rights are not infringed upon when integrating MPS products into any application. MPS will not assume any legal responsibility for any said applications.