

DESCRIPTION

The MP26085 is a voltage and current control IC integrated a precision voltage reference and a current source, which is suitable for battery charger, second controller of switching regulator systems, and other types of application required an accurate voltage and current control systems.

This IC compares the DC voltage and the current level at the output of a switching power supply to the voltage reference and current limitation, respectively. It provides a feedback through an opto-coupler to the PWM controller IC at the primary side.

The current source is controlled externally, which can be used to modify the level of current limitation by offsetting the information coming from the current sensing resistor.

It is available in an 8-pin TSOT23 package.

FEATURES

- Constant Voltage and Constant Current Control
- 1.223V built-in voltage reference with 1% Accuracy
- Wide input voltage range: 7V to 20V
- Two Operational Amplifier with ORED Output and 1MHz bandwidth
- Built-in Current Generator with Enable/Disable Function
- 8-Pin TSOT23 Package

APPLICATIONS

- Battery Chargers
- Every Types of Application Required an Accurate Voltage and Current Control

All MPS parts are lead-free, halogen free, and adhere to the RoHS directive. For MPS green status, please visit MPS website under Quality Assurance. "MPS" and "The Future of Analog IC Technology" are Registered Trademarks of Monolithic Power Systems, Inc.

TYPICAL APPLICATION

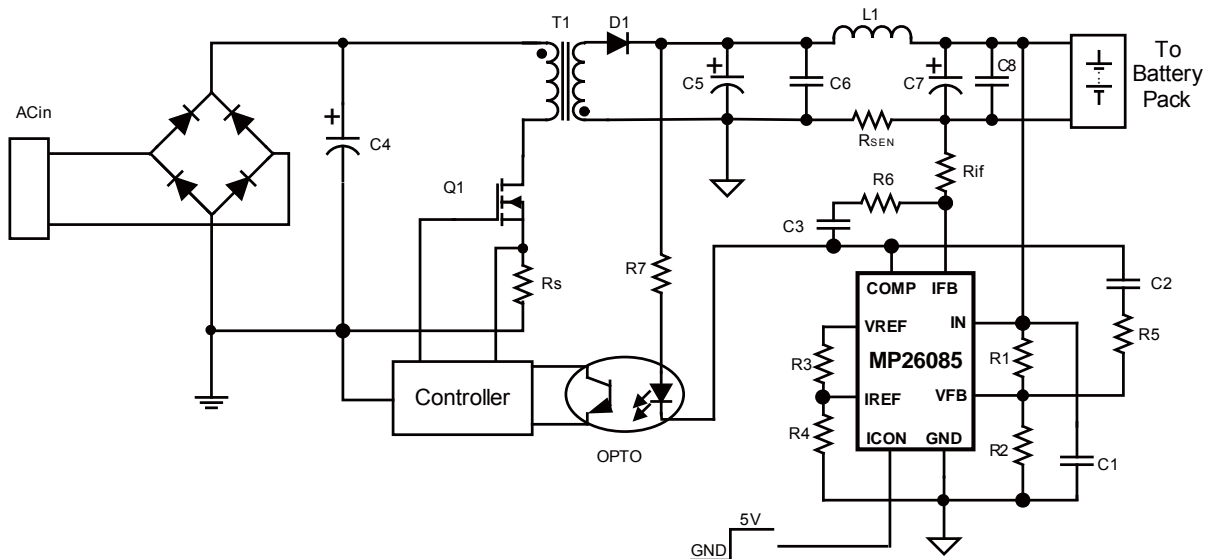

ORDERING INFORMATION

Part Number*	Package	Top Marking	Free Air Temperature Range (T _A)
MP26085DJ	TSOT23-8	AAX	-40°C to +85°C

* For Tape & Reel, add suffix –Z (e.g. MP26085DJ–Z);
 For RoHS, compliant packaging, add suffix –LF (e.g. MP26085DJ–LF–Z).

PACKAGE REFERENCE

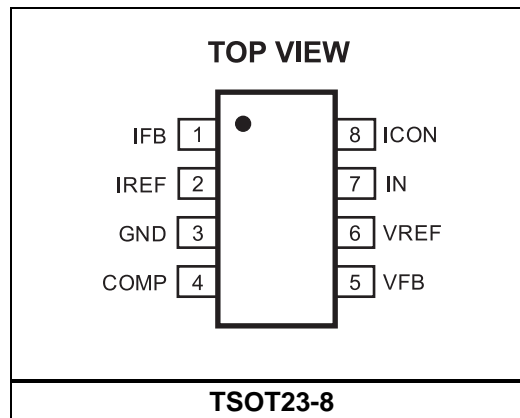

ABSOLUTE MAXIMUM RATINGS ⁽¹⁾

IN Pin	-0.3V to 22V
COMP Pin	-0.3V to 22V
All Other Pins	-0.3V to 6.5V
Continuous Power Dissipation (T _A =25°C) ⁽²⁾	
TSOT23-8	0.45W
Storage Temperature Range....	-65°C to 150°C

Recommended Operating Conditions ⁽³⁾

Supply Input Voltage	7V to 20V
Maximum Junction Temp. (T _J).....	+125°C

Thermal Resistance ⁽⁴⁾	θ_{JA}	θ_{JC}
TSOT23-8.....	220	110.. °C/W

Notes:

- 1) Exceeding these ratings may damage the device.
- 2) The maximum allowable power dissipation is a function of the maximum junction temperature T_J (MAX), the junction-to-ambient thermal resistance θ_{JA} , and the ambient temperature T_A. The maximum allowable continuous power dissipation at any ambient temperature is calculated by P_D (MAX) = (T_J (MAX)-T_A)/ θ_{JA} . Exceeding the maximum allowable power dissipation will cause excessive die temperature, and the regulator will go into thermal shutdown. Internal thermal shutdown circuitry protects the device from permanent damage.
- 3) The device is not guaranteed to function outside of its operating conditions.
- 4) Measured on JESD51-7, 4-layer PCB.

ELECTRICAL CHARACTERISTICS

$V_{IN} = 15V$, $T_A = 25^{\circ}C$, unless otherwise noted.

Parameter	Symbol	Condition	Min	Typ	Max	Units
Total Supply Current	I_{IN}	$V_{IN} = 15V$, $I_{CON}=5V$, no load		0.2		mA
OPERATIONAL AMPLIFIER						
Input Voltage Range ⁽⁵⁾	V_I		0		3	V
Input Offset Voltage	V_{OS}	$T_A = 25^{\circ}C$	-5	1	+5	mV
Input Bias Current	I_B	$T_A = 25^{\circ}C$	-700	-300	0	nA
Output Sink Current	I_{COMP_sink}	$T_A = 25^{\circ}C$, $V_{COMP}=0.5V$		15		mA
		$-40^{\circ}C \leq T_A \leq +85^{\circ}C$	8			
Large Signal Voltage Gain ⁽⁵⁾	A_{VO}	$R_L = 2k\Omega$,		15		V/mV
Supply Voltage Rejection Ratio ⁽⁵⁾	SVR	Supply Voltage change of 1.0V	65	90		dB
Common Mode Rejection Ratio ⁽⁵⁾	CMRR			80		dB
Gain Bandwidth Product ⁽⁵⁾	GBW	$V_{IN} = 15V$, $V_I = 10mV$, $R_L = 2k\Omega$, $C_L = 100pF$		1		MHz
Output Leakage Current	$I_{COMP_leakage}$	$T_A = 25^{\circ}C$			2	μA
VOLTAGE REFERENCE						
Reference Voltage	V_{REF}	$I_{OUT} = 1mA$, $T_A = 25^{\circ}C$	1.21	1.223	1.236	V
Temperature Coefficient	TC_V	$-40^{\circ}C \leq T_A \leq +85^{\circ}C$		60	100	ppm/ $^{\circ}C$
CURRENT GENERATOR						
Current Source	I_{SOURCE}	$R3+R4=44k\Omega$		1.25		mA
Temperature Coefficient	TC_I	$-40^{\circ}C \leq T_A \leq +85^{\circ}C$		100		ppm/ $^{\circ}C$
Line Regulation of Current Source ⁽⁶⁾		$7V < V_{IN} < 20V$		0.003	0.03	mA
Voltage at ICON pin to enable	V_{ICON_EN}	$I_{SOURCE} = 1.25mA$			0.6	V
Voltage at ICON pin to disable	V_{ICON_DIS}	$I_{SOURCE} = 0mA$	2			V
Input Current on the ICON pin	$ICON_{IN}$	$V_{ICON}=6.5V$			30	μA
ICON pin source Current	$ICON_{IN}$	$V_{ICON}=0V$			30	μA

Notes:

5) Guaranteed by design.

6) Line Regulation = $I_{SOURCE(VCC_MAX)} - I_{SOURCE(VCC_MIN)}$

PIN FUNCTIONS

Package Pin #	Name	Description
1	IFB	Current feedback. Connected to the sense resistor.
2	IREF	Current Limitation Reference Input. An external resistor divider (sum is 44kΩ) from the VREF to GND tapped to the IREF pin sets the current reference.
3	GND	Ground
4	COMP	Output pin common to the voltage regulation and current limitation loops. This output can drive the primary side (LED) of an opto-coupler.
5	VFB	Voltage feedback. An external resistor divider from the output to GND tapped to the FB pin sets the output voltage.
6	VREF	Internal voltage reference output. This voltage is used to generate the voltage and current reference.
7	IN	Power Supply Input. Bypass VIN to GND with a 4.7μF or greater capacitor.
8	ICON	Current source enable input. This current source can be used to offset the voltage measurement on the sense resistor and therefore to modify the charge current. The current source enabled when the input voltage on ICON pin is lower than 0.6V.

TYPICAL PERFORMANCE CHARACTERISTICS

$T_A = 25^\circ\text{C}$, unless otherwise noted.

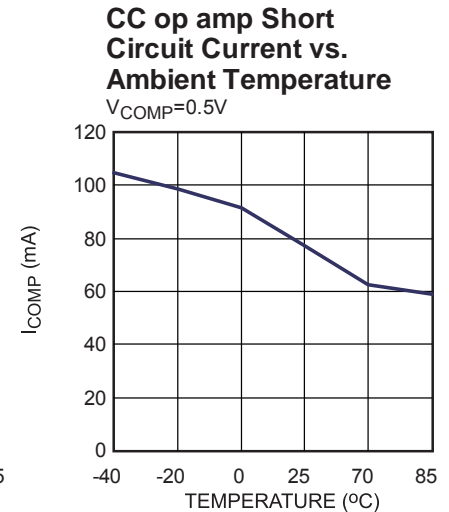
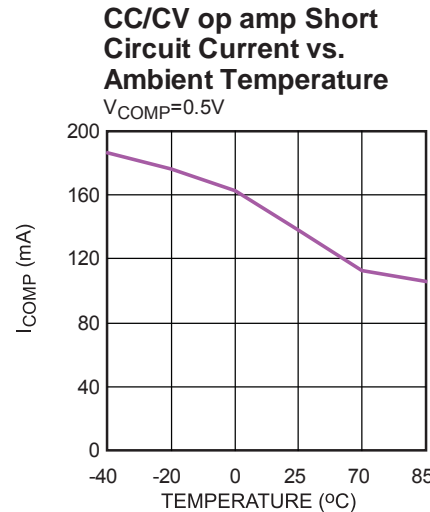
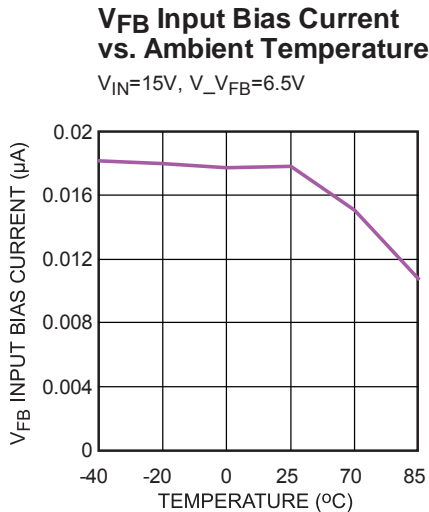
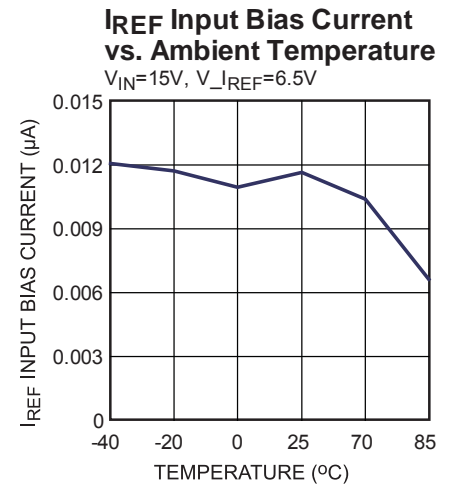
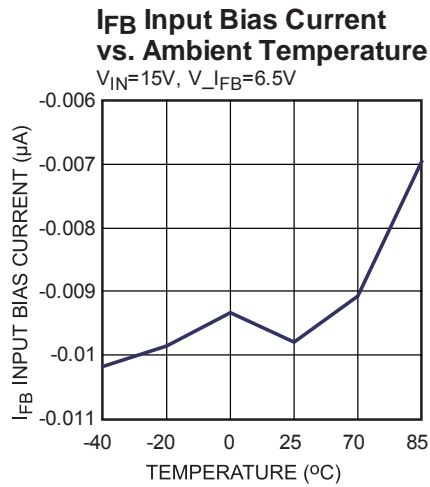
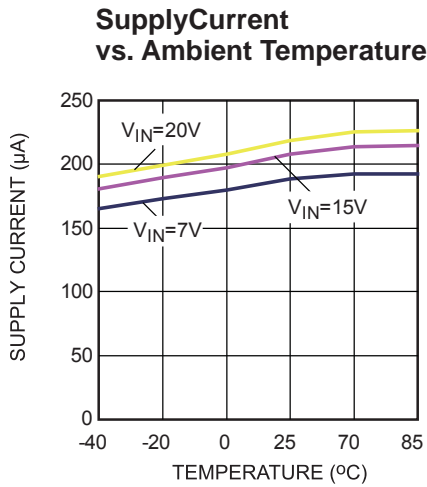
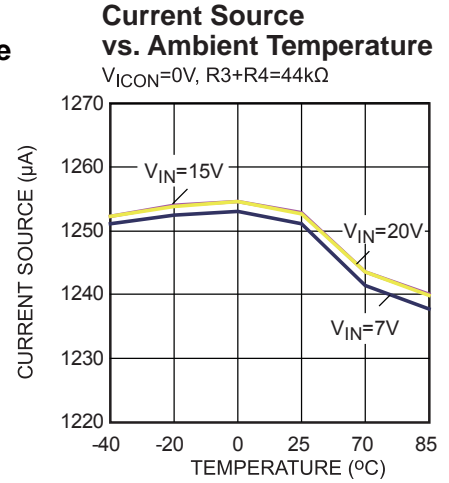
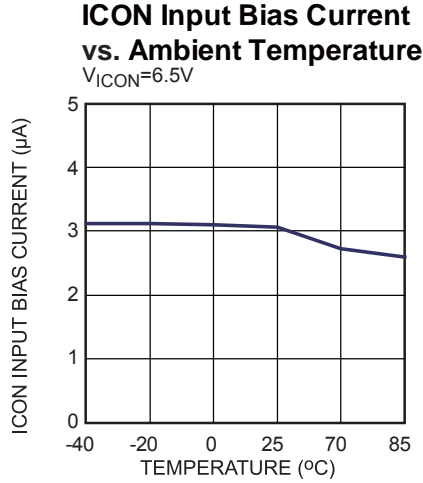
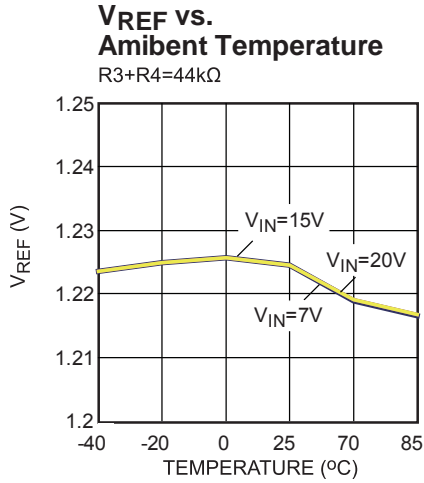

TYPICAL PERFORMANCE CHARACTERISTICS (Continued)

T_A = 25°C, unless otherwise noted.

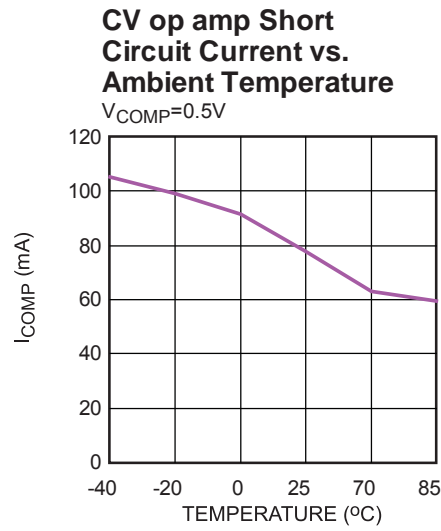

OPERATION

The MP26085 integrates a high precision band gap voltage reference, two operational amplifiers and a current source (Figure 1). It is intended for use in a switching mode power supply (SMPS) to realize constant current and constant voltage control.

Voltage Reference

The voltage reference of MP26085 is 1.223V.

Voltage Regulation Loop

The voltage regulation is done by comparing the feedback output voltage (resistor divider R1 and R2) to the voltage reference (1.223V). If it is higher than 1.223V, the output of the voltage loop operational amplifier decreases. The optocoupler current increases and tends to reduce the output voltage by the way of the PWM controller.

Current Limitation Loop

The current limitation is performed by sensing the voltage across the low ohmic value resistor R_{SEN} and comparing it to a fixed value set by the R-divider composed by R3 and R4 ($R3+R4=44k\Omega$ in the typical application circuit). When the voltage on R_{SEN} is higher than the

voltage on the IREF pin the output of the current loop operational amplifier decreases. The optocoupler current increases and tends to reduce the output voltage by the way of the PWM controller.

Current Source

The current source of MP26085 is controlled by the ICON pin

By connecting the ICON pin to the ground, the current source is enabled. MP26085 mirrors the current through V_{REF} pin to generate the current source with the gain $K_i=45$. The current goes through V_{REF} pin is determined by the external R-divider, R3 and R4 (typical application circuit). So, the current source is calculated as:

$$I_{SOURCE} = K_i \times \frac{V_{REF}}{R3 + R4}$$

Then, we can offset the sensing output current by a voltage equal to:

$$V_{OFFSET} = R_{if} \times I_{SOURCE}$$

This offset lowers the output current and this function can be used to charge batteries with different capacities.

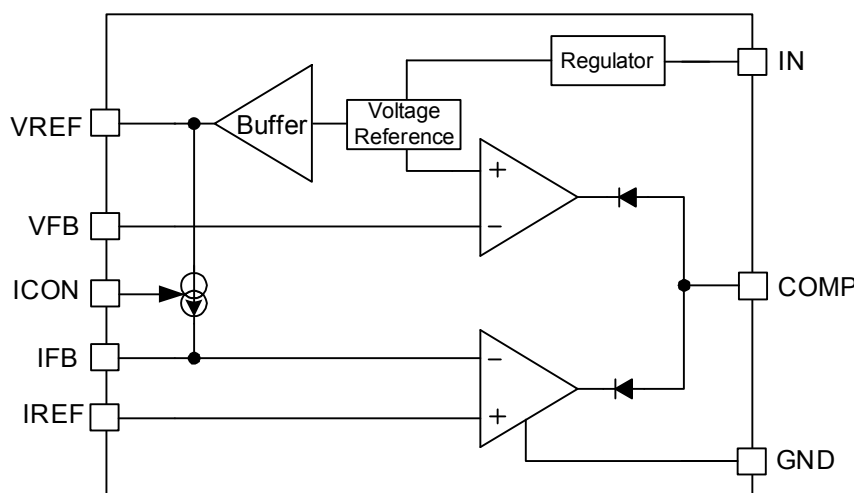

Figure 1—Block Diagram

APPLICATION INFORMATION

Setting the Constant Output Voltage

The output voltage is set by selecting the resistive voltage divider ratio. The voltage divider drops the charge voltage to the internal voltage reference 1.223V. Generally, use 10kΩ for the low-side resistor of the voltage divider. Determine the high-side resistor by the equation:

$$R1 = R2 \times \left(\frac{V_o}{1.223V} - 1 \right)$$

Where R1 is the high-side resistor, R2 is the low-side resistor and V_o is the constant output voltage.

Setting the Constant Output Current /Current Limitation

The output current is regulated effectively when the voltage drop across R_{SEN} is equal to the voltage on IREF pin of the MP26085 (assuming that the internal current source is disabled). R_{SEN} is the sense resistor used for current measurement.

For general application (<1A), the voltage drop across R_{SEN} is recommended to be 200mV. R_{SEN} can be standard low cost 0.5W resistors in parallel.

$$R_{SEN} = \frac{V_{IREF}}{I_o}$$

The output current is set by scaling V_{REF} through R3 and R4:

$$V_{IREF} = \frac{R4}{R3 + R4} \times V_{REF}$$

The ratio of R3 and R4 determines the current reference, and the sum of the resistances of R3 and R4 sets the current source. So, it is recommended to set the sum of R3 and R4 to get current source first (recommended 44kΩ), then select a suitable ratio between R3 and R4 to achieve the current reference value.

Output Current Adjustment

If the ICON pin is left open or connected to 5V V_{CC} , the output current is determined by the IREF and sensing resistor R_{SEN} .

$$I_o = \frac{V_{IREF}}{R_{SEN}}$$

If ICON pin is connected to ground, the internal current source is enabled, the current measurement is off-set by a voltage equal to:

$$V_{OFFSET} = R_{if} \times K_i \times \frac{V_{REF}}{R3 + R4}$$

This can be used to lower the output current for trickle charge or eventually to stop the charge.

TYPICAL APPLICATION CIRCUITS

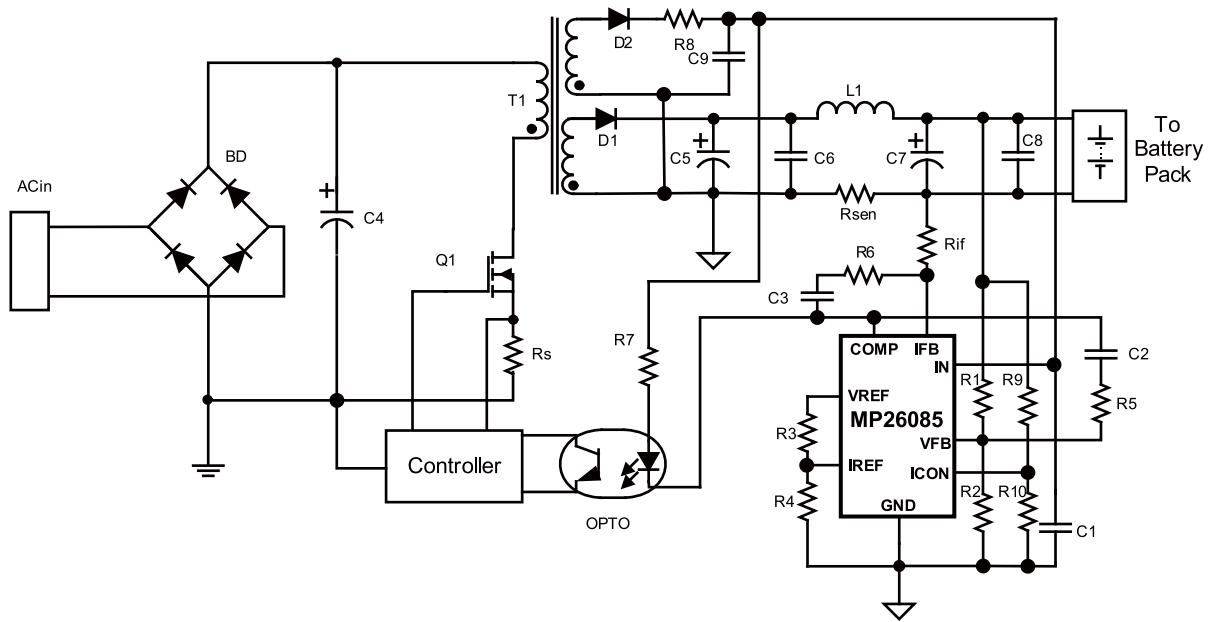

Figure 2— Adapter / Battery Charger Using MP26085 with Auxiliary Winding

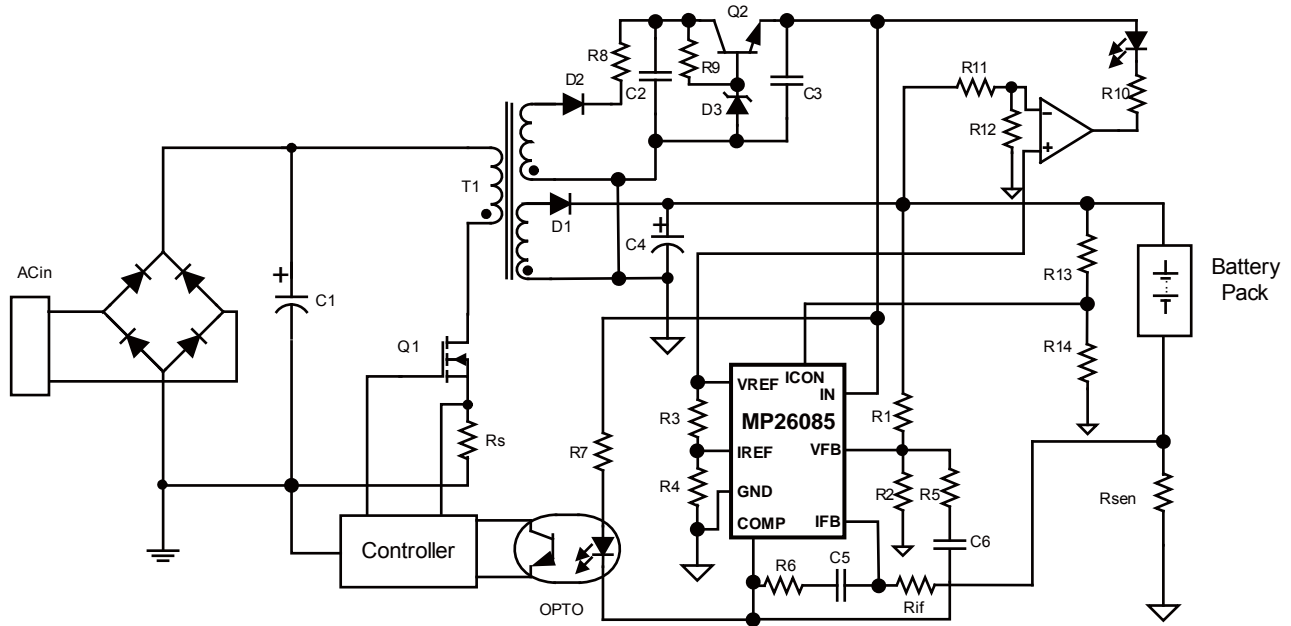

Figure 3—Charger with Trickle Charge and LED Indication Using MP26085

The MP26085 also can be used in LED lighting to realize the analog dimming or digital dimming control, Figure 4 shows single stage flyback with MP26085, the single stage flyback is controlled by MP44010, two dimming functions are realized by MP26085.

When analog dimming control is adopted, the I_{ref} is generated from the analog dimming signal. R31 is 0, R30 and Q4 is not connected, the system output current for LED is controlled by analog dimming signal, I_{ref} is $\frac{R35}{R36 + R34 + R35} \times V_a$, where V_a is the amplitude of the analog dimming signal.

When digital dimming control is adopted, the I_{ref} is generated from V_{ref} . R30 is 0, R31 is not connected, Q4 is controlled by the digital dimming signal to adjust the LED current reference. When the digital dimming signal is high, Q4 is on, I_{ref} is $\frac{R35}{R34 + R35} \times V_{ref}$, when the digital dimming signal is low, Q4 is off, I_{ref} is 0. So the LED current is controlled by the duty of digital dimming signal.

Figure 5 is a typical application for charger with MP26085, HFC0100, and MP6902, the input voltage is 85V~265V AC, output 36V DC, 1.8A. HFC0100 is a quasi resonant controller for fly back, and MP6902 is a fast turn-off intelligent rectifier.

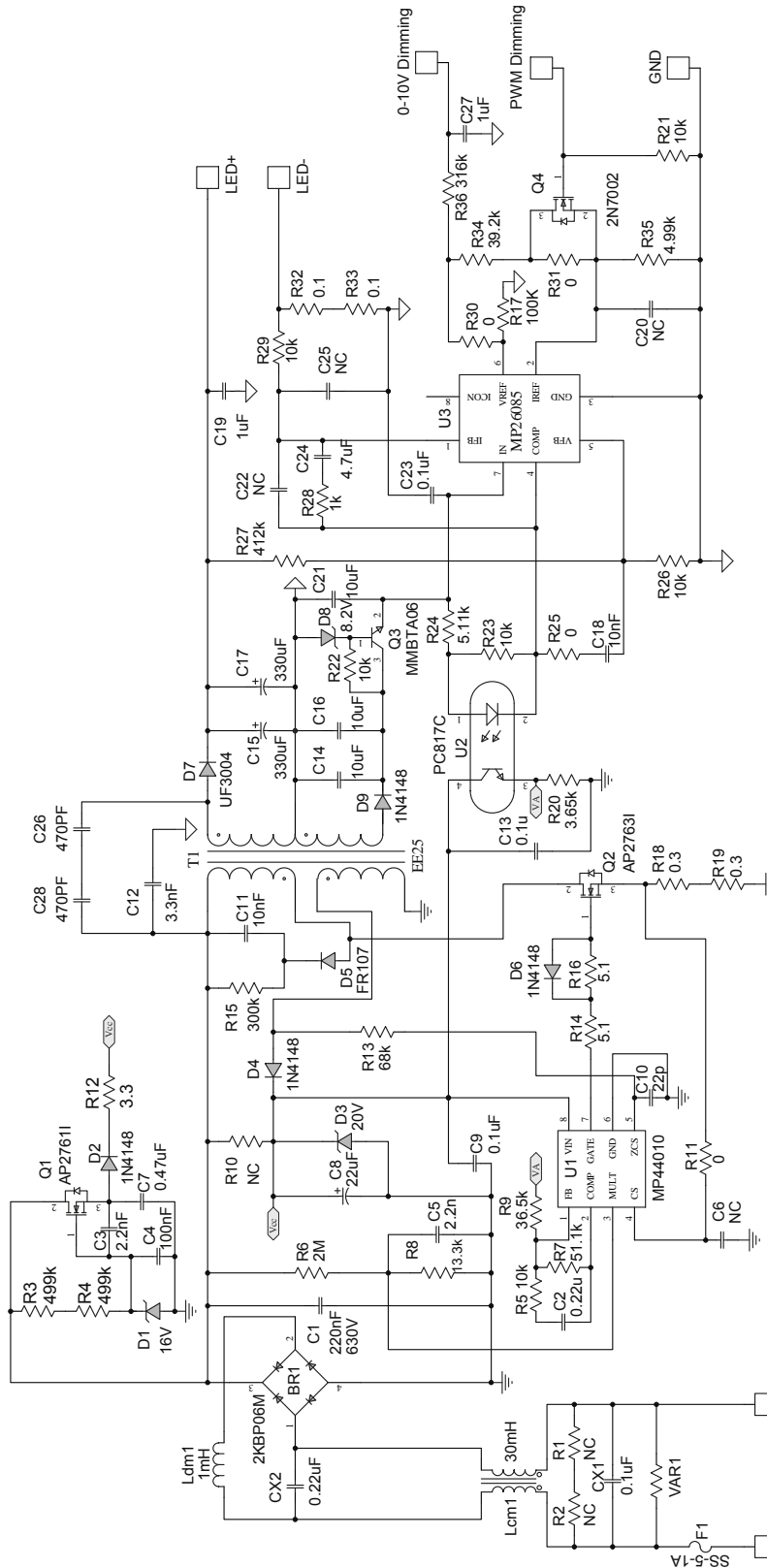

Figure 4—Single Stage Flyback Using MP26085 for LED Lighting

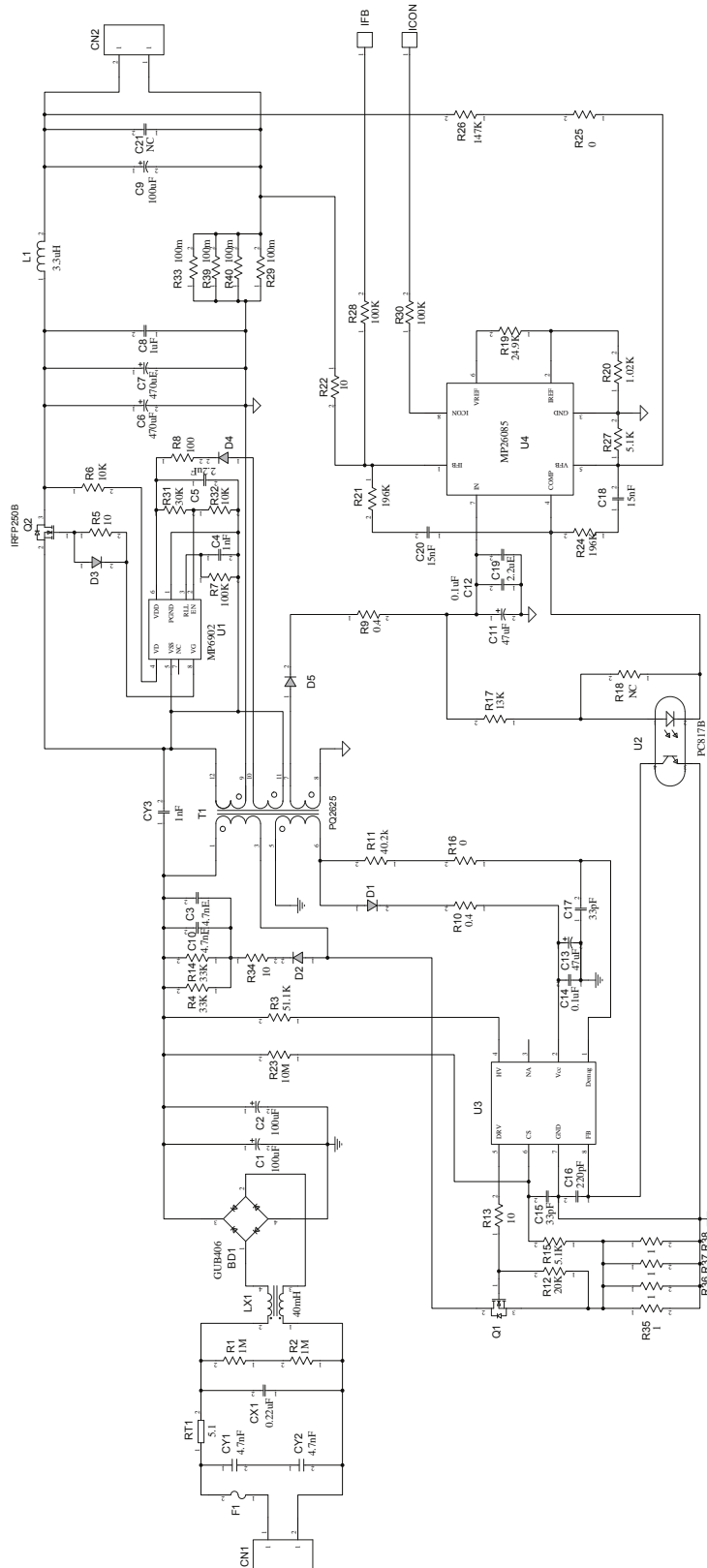
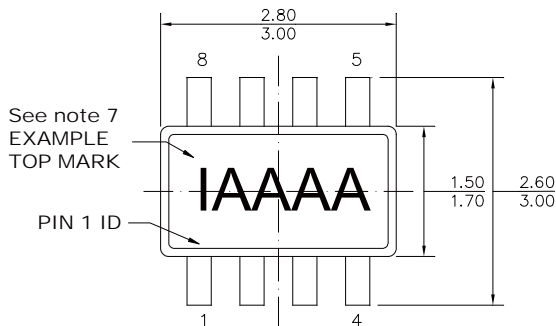

Figure 5— Application Circuit of MP26085 for Charger

PACKAGE INFORMATION

TSOT23-8



TOP VIEW

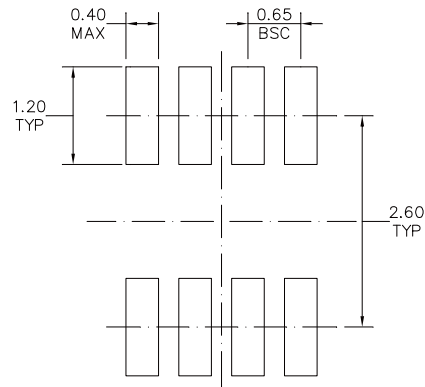

RECOMMENDED LAND PATTERN

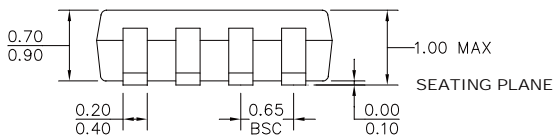

FRONT VIEW

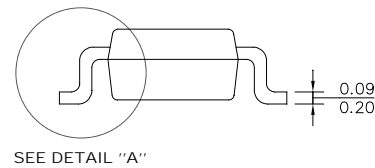

SIDE VIEW

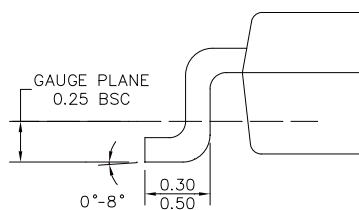

DETAIL "A"

NOTE:

- 1) ALL DIMENSIONS ARE IN MILLIMETERS.
- 2) PACKAGE LENGTH DOES NOT INCLUDE MOLD FLASH, PROTRUSION OR GATE BURR.
- 3) PACKAGE WIDTH DOES NOT INCLUDE INTERLEAD FLASH OR PROTRUSION.
- 4) LEAD COPLANARITY (BOTTOM OF LEADS AFTER FORMING) SHALL BE 0.10 MILLIMETERS MAX.
- 5) JEDEC REFERENCE IS MO-193, VARIATION BA.
- 6) DRAWING IS NOT TO SCALE.
- 7) PIN 1 IS LOWER LEFT PIN WHEN READING TOP MARK FROM LEFT TO RIGHT, (SEE EXAMPLE TOP MARK)

NOTICE: The information in this document is subject to change without notice. Please contact MPS for current specifications. Users should warrant and guarantee that third party Intellectual Property rights are not infringed upon when integrating MPS products into any application. MPS will not assume any legal responsibility for any said applications.