

DESCRIPTION

EV3908+8002-00A is designed as the Power over Ethernet (PoE) Powered Device (PD) module. An RJ-45 connector is provided to connect directly to an Ethernet cable having a Power Sourcing Equipment (PSE) driving it on the other end. It also accepts power applied using a stand-alone power supply.

According to the IEEE 802.3at specification, the PD module must provide the circuitry needed to be detected by the PSE as it polls the Ethernet links. The IEEE 802.3at specification also allows the option for the PD to provide classification as to the amount of power needed by the PD Module. EV3908+8002-00A with the MP8002DN provides all the necessary hardware to provide detection and classification together with programmable inrush current limit, power good indicator, thermal protection and current limit. An external 30W Flyback converter is connected as the PWM part of the PD, which is controller by the synchronous PWM controller MP3908DS with soft-start, slope compensation and peak current limiting.

FEATURES

- Meets IEEE 802.3at Specifications
- 100V, 0.8Ω Integrate DMOS Device in MP8002DN
- 450mA, Temperature Compensated Current Limit
- Open Drain Power Good Output
- Synchronous Rectification for MP3908
- Current Mode Control
- Soft-Start
- 250kHz Constant Frequency Operation

APPLICATIONS

- VoIP Telephones
- Network Cards
- Security Camera Systems
- Safety Backup Power
- Remote Internet Power

ELECTRICAL SPECIFICATIONS

Parameter	Symbol	Value	Units
Input Voltage	V _{IN}	40 – 57	V
Output Voltage	V _{OUT}	5	V
Output Current	I _{OUT}	0-6	A

"MPS" and "The Future of Analog IC Technology" are Registered Trademarks of Monolithic Power Systems, Inc.

EV3908+8002-00A EVALUATION BOARD

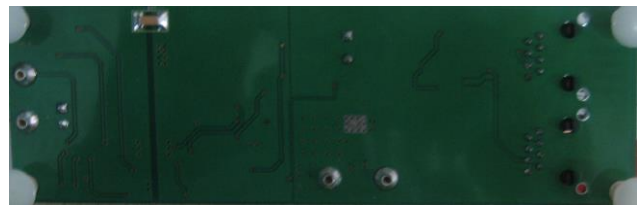

(L x W x H) 5.4" x 1.7" x 0.8"
(13.8cm x 4.3cm x 2.0cm)

Board Number	MPS IC Number
EV3908+8002-00A	MP3908DK, MP8002DN

EVALUATION BOARD SCHEMATIC

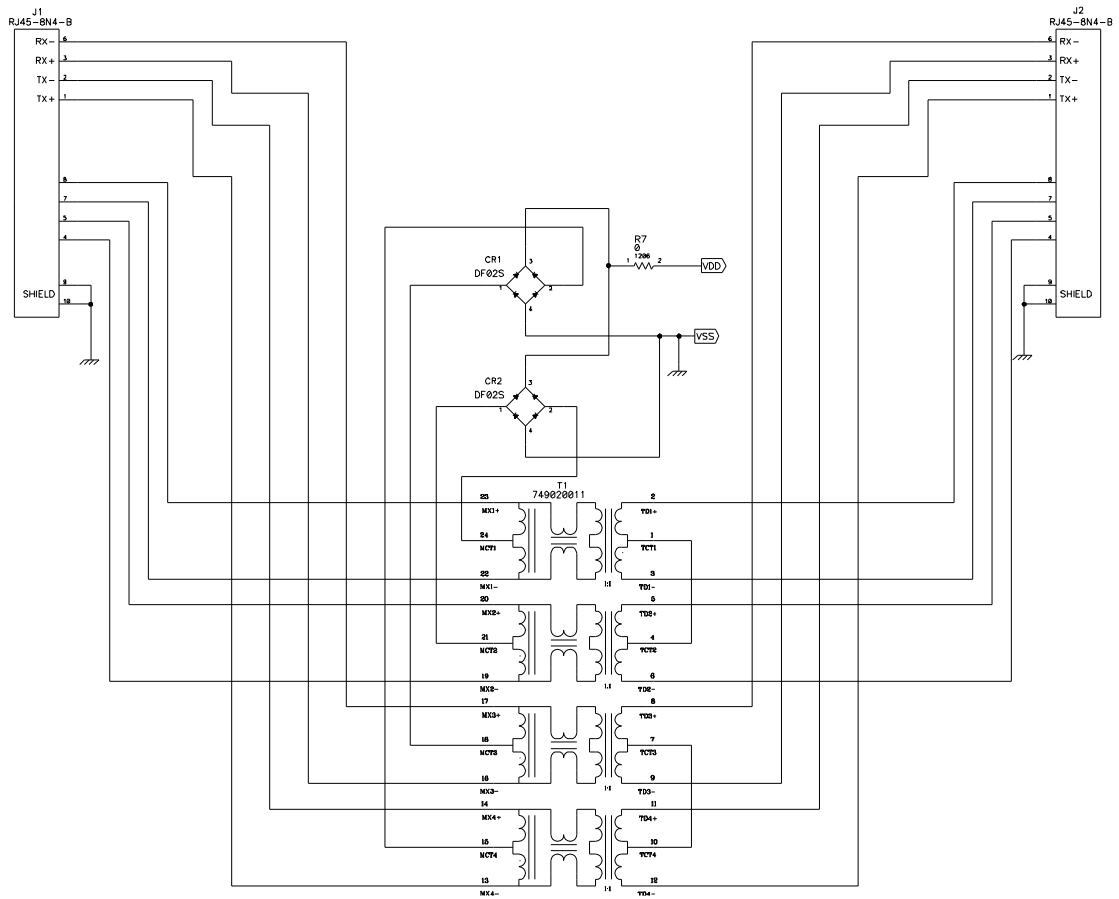

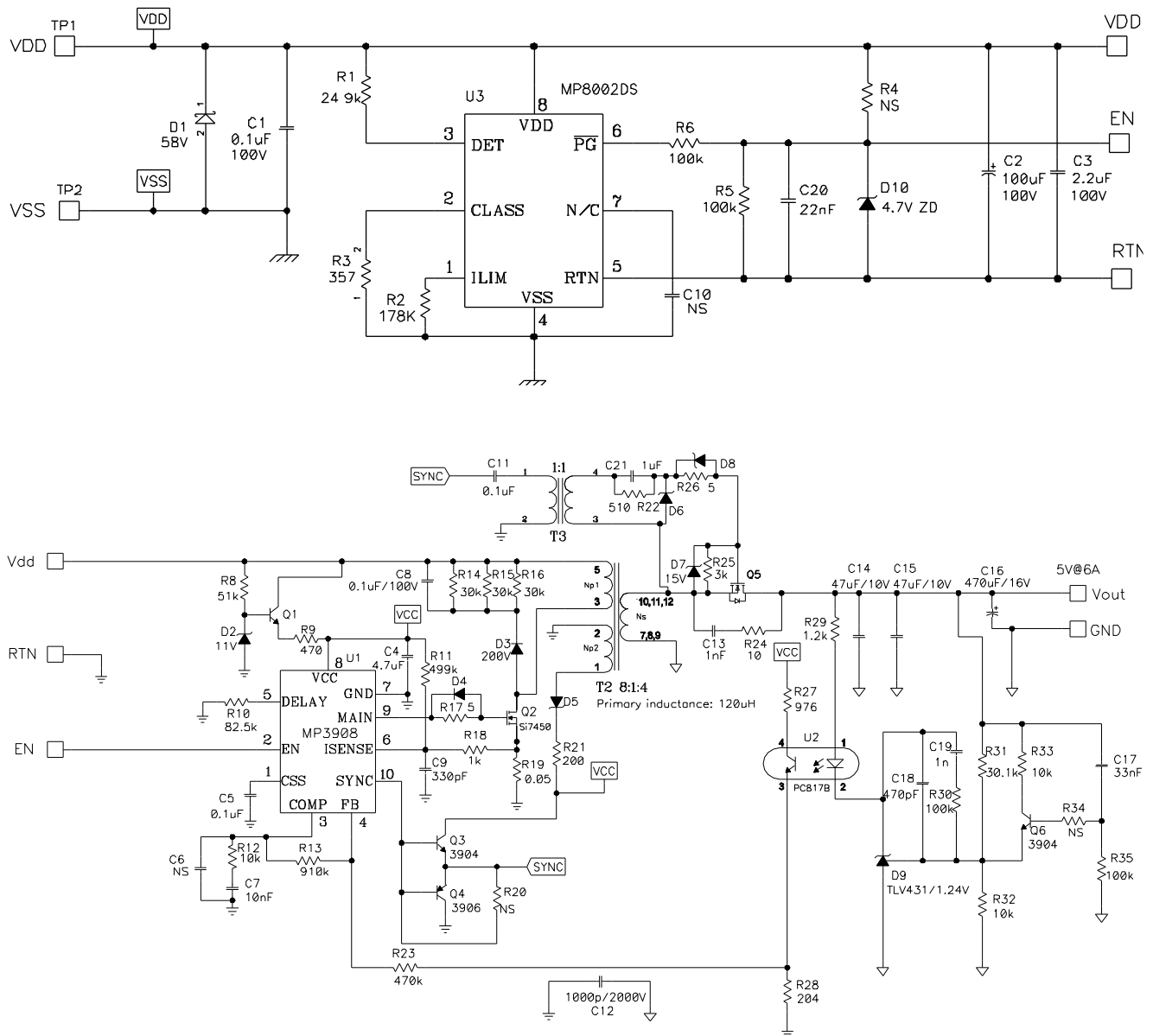

EV3908+8002-00A BILL OF MATERIALS

Qty	Ref	Value	Discription	Package	Manufacturer	Manufacturer P/N
1	C1	0.1uF	Ceramic Cap. 100V X7R	1206	muRata	GRM319R72A104KA01L
1	C2	100uF	100V Electrolytic	DIP		
1	C3	2.2uF	Ceramic Cap. 100V X7R	1210	muRata	GRM32ER72A224KA35L
1	C4	4.7uF	Ceramic Cap. 25V X7R	1206	TDK	C3216X7R1E475K
2	C5	0.1uF	Ceramic Cap. 50V X7R	0603	TDK	C1608X7R1H104K
2	C6,C10	NS				
1	C7	10nF	Ceramic Cap. 50V X7R	0603	TDK	C1608X7R1H103K
1	C8,C11	0.1uF	Ceramic Cap. 100V X7R	0805	TDK	C2012X7R2A104K
1	C9	330pF	Ceramic Cap. 50V X7R	0603	TDK	C1608X7R1H331K
1	C12	1nF	Ceramic Cap. 2000V X7R	1812	TDK	C4520X7R3D102K
2	C13,C19	1nF	Ceramic Cap. 50V X7R	0603	TDK	C1608X7R1H102K
2	C14,C15	47uF	Ceramic Cap. 10V X5R	1210	TDK	C3225X5R1C475K
1	C16	470uF	16V Electrolytic	DIP		
1	C17	33nF	Ceramic Cap. 50V X7R	0603	TDK	C1608X7R1H333K
1	C18	470pF	Ceramic Cap. 50V X7R	0603	TDK	C1608X7R1H471K
1	C20	22nF	Ceramic Cap. 50V X7R	0603	TDK	C1608X7R1H223K
1	C21	1uF	Ceramic Cap. 16V X7R	0603	TDK	C1608X7R1C105K
1	R1	24.9k	Film Resistor 1%	0603	Yageo	RC0603FR-0724K9L
1	R2	178k	Film Resistor 1%	0603	Yageo	RC0603FR-07178KL
1	R3	357	Film Resistor 1%	1206	Yageo	RC1206FR-07357RL
1	R4	NS				
3	R5,R6,R30,R35	100k	Film Resistor 5%	0603	Yageo	RC0603JR-07100KL
1	R7	0	Film Resistor 5%	1206	Yageo	RC1206JR-070RL
1	R8	51k	Film Resistor 5%	0603	Yageo	RC0603JR-0751KL
1	R9	470	Film Resistor 5%	0603	Yageo	RC0603JR-07470RL
1	R10	82.5k	Film Resistor 1%	0603	Yageo	RC0603FR-0782K5L
1	R11	499k	Film Resistor 1%	0603	Yageo	RC0603FR-07499KL
3	R12,R32,R33	10k	Film Resistor 1%	0603	Yageo	RC0603FR-0710KL
1	R13	910k	Film Resistor 5%	0603	Yageo	RC0603JR-07910KL
3	R14,R15,R16	30k	Film Resistor 5%	0805	Yageo	RC0805JR-0730KL
2	R17,R26	5.1	Film Resistor 5%	0603	Yageo	RC0603JR-075R1L
2	R18,R29	1k	Film Resistor 5%	0603	Yageo	RC0603JR-071KL
1	R19	50m Ω	Strip Resistor 1%	1206	CYNTEC	RL1632H-R050-FN
2	R20,R34	NS				
1	R21	200	Film Resistor 5%	0603	Yageo	RC0603JR-07200RL
1	R22	510	Film Resistor 5%	0603	Yageo	RC0603JR-07510RL

EV3908+8002-00A BILL OF MATERIALS (continued)

Qty	Ref	Value	Discription	Package	Manufacturer	Manufacturer P/N
1	R23	470k	Film Resistor 5%	0603	Yageo	RC0603JR-07470KL
1	R24	10	Film Resistor 5%	0805	Yageo	RC0805JR-0710RL
1	R25	3k	Film Resistor 5%	0603	Yageo	RC0603JR-073KL
1	R27	976	Film Resistor 1%	0603		RC0603FR-07976RL
1	R28	205	Film Resistor 1%	0603	Yageo	RC0603FR-07204RL
1	R31	30.1k	Film Resistor 1%	0603	Yageo	RC0603FR-0730K1L
1	D1	58V	DIODE ZENER 58V	SMA	Diodes Inc	SMAJ58A
1	D2	10V	DIODE ZENER 10V	SOD-123	Diodes Inc	BZT52C10
1	D3	BAV21	Switching Diode 200V 200mW	SOD-123	Diodes Inc	BAV21W-7-F
4	D4,D5,D 6,D8	1N414 8	Switching Diode 75V 250mW	SOD323	Diodes Inc	1N4148WS-7
1	D7	15V	DIODE ZENER 15V	SOD-123	Diodes Inc	BZT52C15
1	D9	TLV43 1A	REG VLT ADJ 1.24V	SOT-23- 5	Zetex Inc	TLV431A
1	D10	4.7V	DIODE ZENER 4.7V	SOD-123	Diodes Inc	BZT52C4V7
3	Q1,Q3,Q 6	NPN	Transistor NPN 40V 350mA	SOT-23	Fairchild	MMBT3904FSCCT
1	Q2	Si7450	N-CH MOSFET 200V 3.9A	POWER PAK SO- 8	Vishay Siliconix	Si7450
1	Q4	PNP	Transistor PNP 40V 350mA	SOT-23	Fairchild	MMBT3906FSCCT
1	Q5	Si4840	N-CH MOSFET 40V 14A	SO-8	Vishay Siliconix	Si4840
2	CR1,CR2	DF02S	1.0A Surface Mount Glass Passivated Bridge Rectifier	DF-S	Diodes Inc	DF02S
1	U1	MP390 8DK	BOOST	MSOP10	MPS	MP3908DK_R0
1	U2	PC817 B	PHOTOCOUP	SMD	SHARP	PC817B
1	U3	MP800 2DS	IEEE 802.3af Powered Device Controller	SO-8	MPS	MP8002DN_R0
1	T1		LAN-TRANSFORMER WE-LAN	SMD	WURTH	749020011
1	T2		POWER STAGE TRANSFORMER	SMD	Cooper	CTX01-18290
1	T3		DRIVER TRANSFORMER	SMD	WURTH	750340060
2	J1,J2	RJ45- 8N4-B	RJ Jack / Signal Line EMI/RFI Filters 6 TRMN BRD/CBLE GRND 8 PIN BLOCK INDUCTOR	RJ45- TAB DOWN	Würth Elektronik	WE-615008137121

PRINTED CIRCUIT BOARD LAYOUT

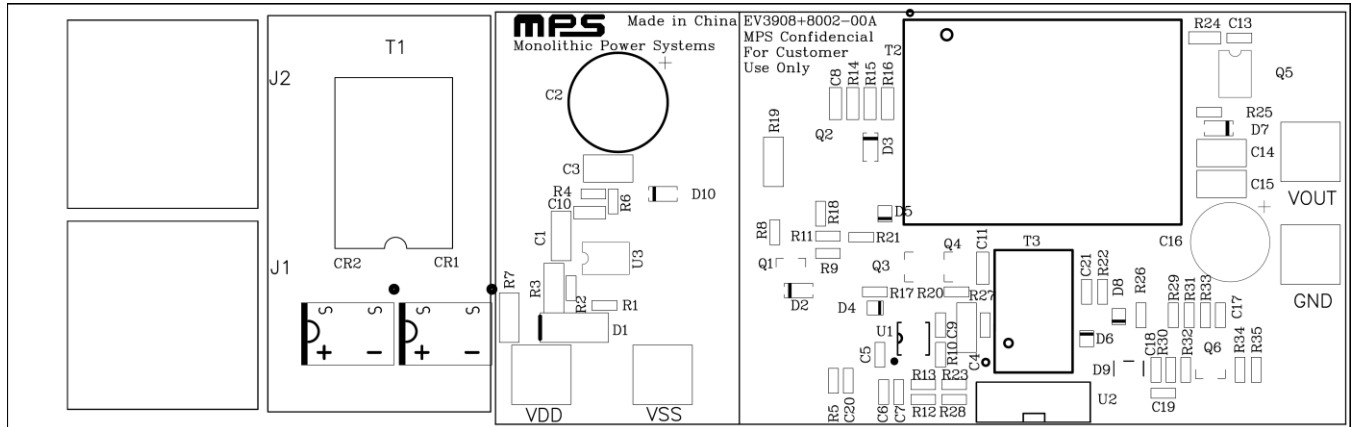

Figure 1—Top Silk Layer

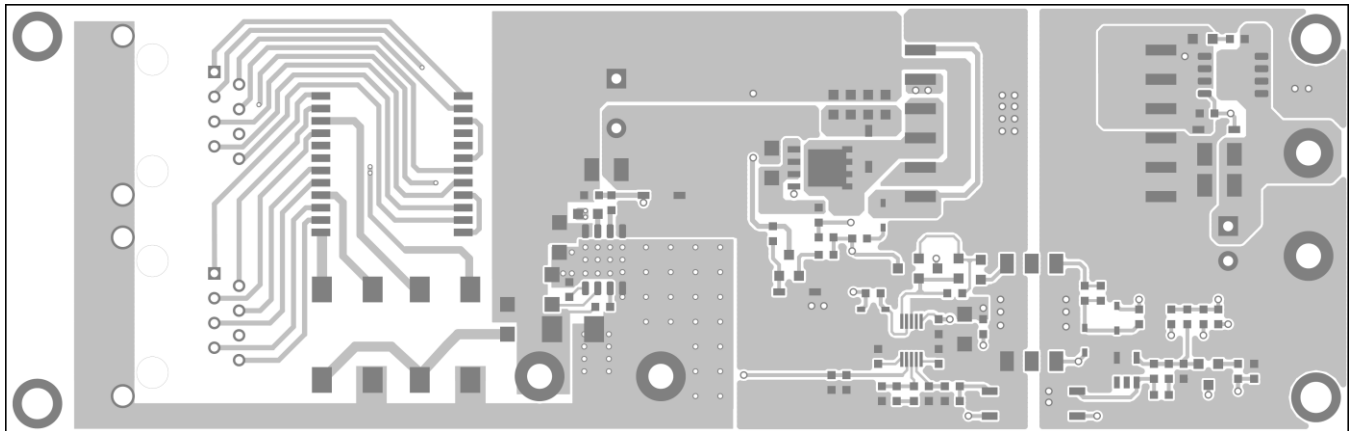

Figure 2—Top Layer

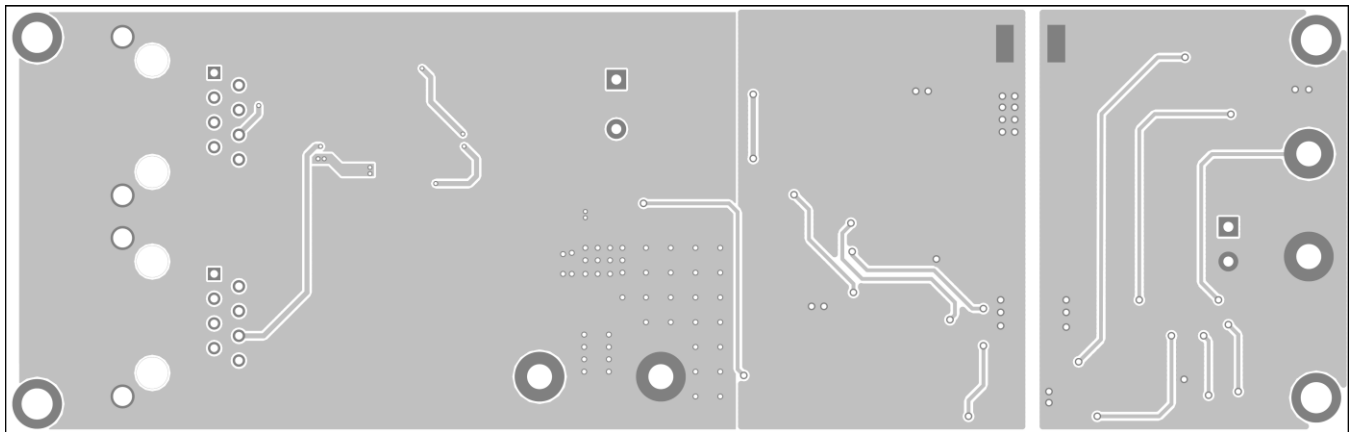

Figure 3—Bottom Layer

QUICK START GUIDE

1. Connect the load between VOUT (positive) and GND (negative) terminals.
2. Plug the cable coming from the PSE, carrying the input voltage for the PD, into the Ethernet Jack J1. The board will automatically startup.
3. External DC supply can also be used. Preset the power supply output to 40V – 57V and turn off the power supply. Connect the positive terminal of the power supply output to the VDD pin and the negative terminal of the power supply output to the VSS pin. Turn the power supply on. The board will automatically startup.

NOTICE: The information in this document is subject to change without notice. Users should warrant and guarantee that third party Intellectual Property rights are not infringed upon when integrating MPS products into any application. MPS will not assume any legal responsibility for any said applications.